



# OMNI™ (R<sup>2</sup>) Water Meter

## 1-1/2" and 2" OMNI R<sup>2</sup> Meter

The OMNI R<sup>2</sup> Water Meter operation is based on advanced Floating Ball Technology (FBT).

### DESCRIPTION:

- Floating Ball Technology (FBT)

### ELECTRONIC REGISTER DISPLAY DIAGRAM



Totalization Mode

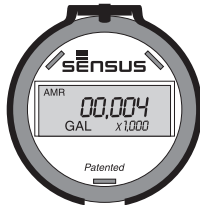

AMR/AMI Mode

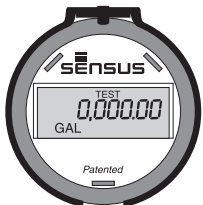

Resettable Test Mode

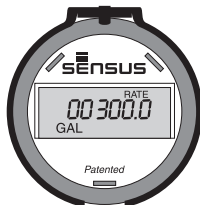

Rate of Flow Mode

### Conformance to Standards

The OMNI R<sup>2</sup> meter meets and far exceeds the most recent revision of ANSI/AWWA Standard C701 class II standards and exceeds performance criteria for ANSI/AWWA C700 Residential Standard using Sensus Turbo technology. Each meter is performance tested to ensure compliance. All OMNI meters are NSF/ANSI Standard 61, Annex F and G approved.

### Performance

The patented measurement principles of the OMNI R<sup>2</sup> meter ensure greater accuracy, expanded accuracy range and longer service life than any other comparable class meter. The OMNI R<sup>2</sup> meter has no restrictions on sustained flow rates within its continuous range. The floating ball measurement technology allows installation in any orientation and flows up to maximum rated capacity without undue wear or accuracy degradation.

### Construction

The OMNI R<sup>2</sup> meter consists of two basic assemblies; the maincase and the measuring chamber. The measuring chamber assembly includes the "floating ball" impeller with a coated titanium shaft, hybrid axial bearings, integral flow straightener and an all electronic programmable register with protective bonnet. The maincase is made from industry proven Ductile Iron with an approved NSF epoxy coating. Maincase features are; easily removable measuring chamber, unique chamber seal to the maincase using a high pressure o-ring, testing port and a convenient integral strainer.

### OMNI Electronic Register

The OMNI R<sup>2</sup> electronic register is hermetically sealed with an electronic pickup containing no mechanical gearing. The large character LCD displays AMR, totalization, rate of flow and a resettable test totalizer. OMNI register features include AMR resolution units that are fully programmable and integral resettable accuracy testing feature compatible with UniPro and Sensus flow verification software. The large, easy-to-read LCD also displays both forward and reverse flow directions. The OMNI R<sup>2</sup> electronic register has a 10-year battery life guarantee.



**Magnetic Drive**

Meter registration is achieved by utilizing a fully magnetic pickup system. This is accomplished by the magnetic actions of the embedded rotor magnets and the ultra sensitive register pickup probe. The only moving component in water is the “floating ball” impeller.

**Measuring Element**

The hydro-dynamically balanced impeller floats between the bearings. The Floating Ball Technology (FBT) allows the measuring element to operate virtually without friction or wear, thus creating the extended upper and lower flow ranges capable on only the OMNI R<sup>2</sup> meter.

**Strainer**

The OMNI R<sup>2</sup> with the “V” shaped strainer uses a stainless steel screen along with Floating Ball Technology (FBT). This creates a design that greatly improves accuracy, even in difficult settings. A removable strainer cover permits easy access to the screen for routine maintenance.

**Maintenance**

The OMNI R<sup>2</sup> meter is designed for easy maintenance. Should any maintenance be required, the measuring chamber and/or strainer cover can be removed independently. Replacement parts or complete measuring chambers are available for repairs. OMNI R<sup>2</sup> replacement measuring chambers may also be utilized to upgrade some third-party meters to achieve increased accuracy and extended service life.

**AMR/AMI Systems**

Meters and Electronic Registers are compatible with current Sensus AMR/AMI systems and other AMI communication systems that use the Sensus UI1203 protocol.

**Guarantee**

Sensus OMNI R<sup>2</sup> Meters are backed by “The Sensus Guarantee.” Ask your Sensus representative for details or see Bulletin G-500.

**Head Loss Curves**

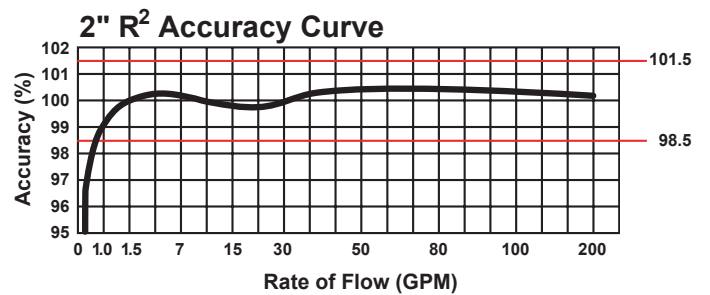
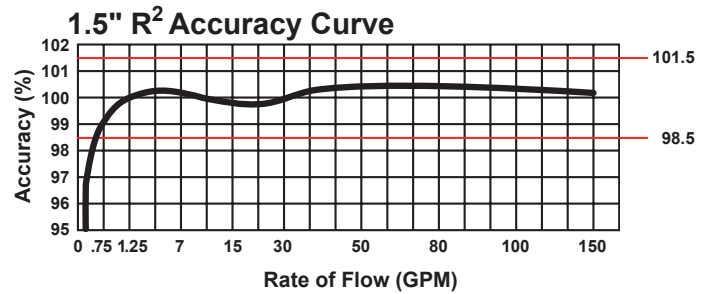
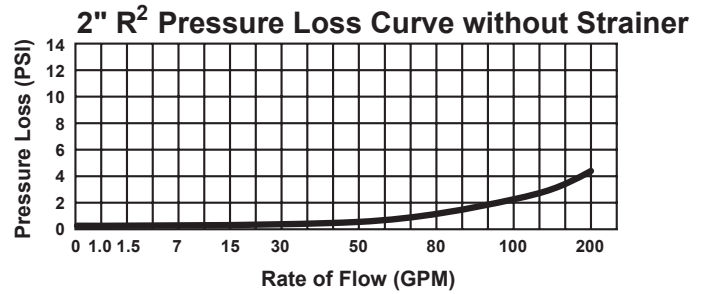
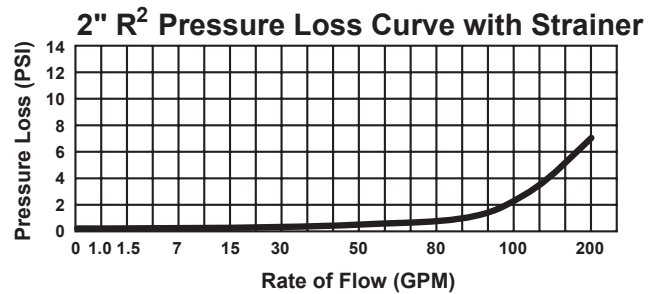
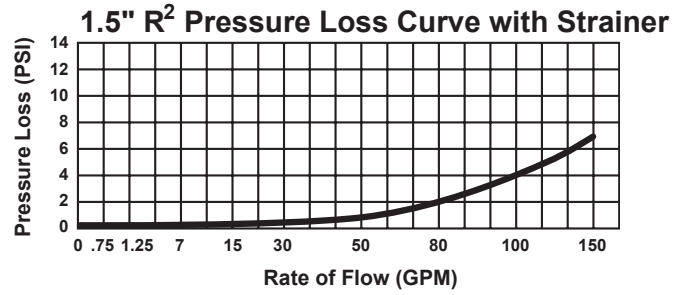



OMNI R<sup>2</sup>: 1-1/2" - 2"

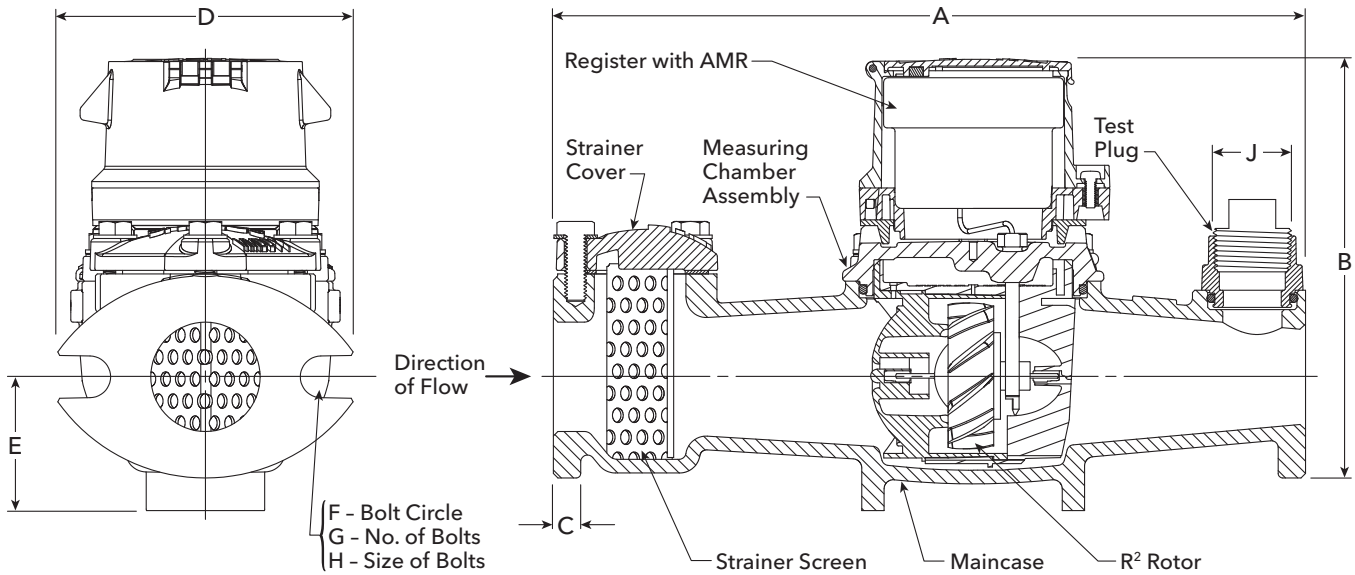

OMNI R<sup>2</sup>: 2" Without Strainer

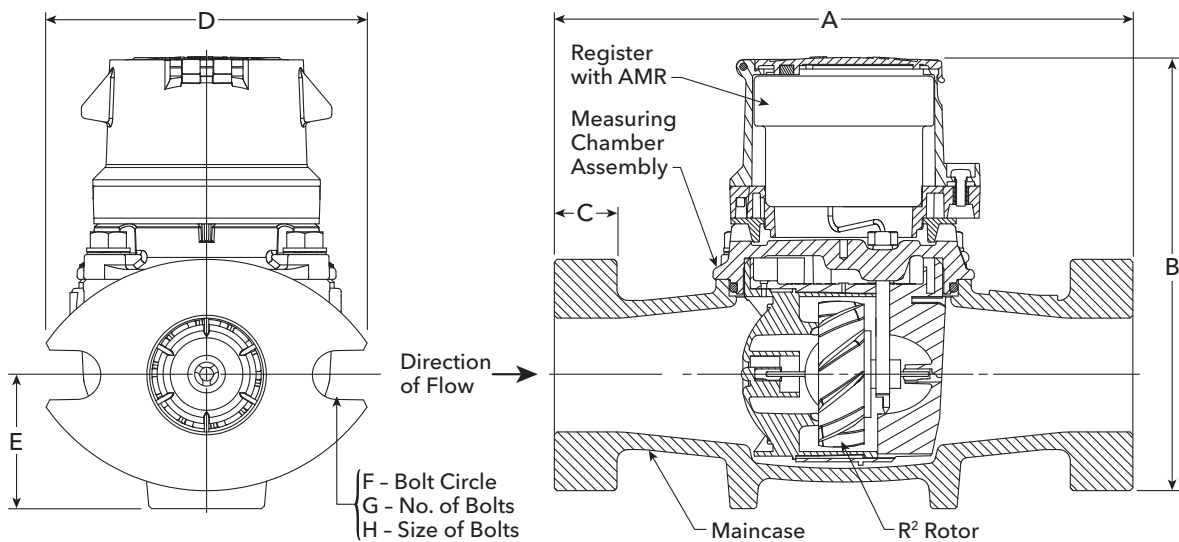

Dimensions and Net Weights

Meter and Pipe Size	Normal Operating Range		Connections	A	B	C	D	E	F	G	H	J	Net Weight	Shipping Weight
1-1/2" DN 40mm	2 gpm 0.45 m <sup>3</sup> /hr	150 gpm 34 m <sup>3</sup> /hr	Flanged	13" 330mm	7-7/8" 200mm	15/16" 24mm	5-1/8" 130mm	2-5/16" 59mm	4" 102mm	2	5/8" 16mm	1" 25mm	18.8 lbs. 8.53 kg.	22.5 lbs. 10.2 kg.
2" DN 50mm	2.5 gpm 0.57 m <sup>3</sup> /hr	200 gpm 45 m <sup>3</sup> /hr	Flanged	17" 432mm	7-7/8" 200mm	1" 25mm	5-3/4" 146mm	2-5/16" 59mm	4-1/2" 114mm	2	3/4" 19mm	1" 25mm	27.4 lbs. 12.4 kg.	34.5 lbs. 15.6 kg.
2" without Strainer DN 80mm	2.5 gpm 0.57 m <sup>3</sup> /hr	250 gpm 57 m <sup>3</sup> /hr	Flanged	10" 254mm	7-7/8" 200mm	1" 25mm	5-3/4" 146mm	2-5/16" 59mm	4-1/2" 114mm	2	3/4" 19mm	N/A	17 lbs. 7.9 kg.	24.5 lbs. 11.1 kg.



## Specifications

Service	Measurement of potable and reclaim water. Storage temperature: -22F (-30C) to 155F (68.3C) Operating temperatures: Air: -22F (-30C) to 150F (65.6C) Water: 33F (0.6C) to 80F (26.7C)
Operating Range (100% ± 1.5%)	1-1/2": 2 - 150 GPM (0.45 - 34 m <sup>3</sup> /hr) 2": 2.5 - 200 GPM (0.57 - 45 m <sup>3</sup> /hr) 2" without Strainer: 2.5 - 250 GPM (0.57 - 57 m <sup>3</sup> /hr)
Low flow (95% - 101.5%)	1-1/2": 0.75 GPM (0.17 m <sup>3</sup> /hr) 2": 1.0 GPM (0.23 m <sup>3</sup> /hr) 2" without Strainer: 2.5 - 250 GPM (0.57 - 57 m <sup>3</sup> /hr)
Pressure Loss	1-1/2": 6.7 psi @ 150 GPM (0.46 bar @ 34 m <sup>3</sup> /hr) 2": 7.0 psi @ 200 GPM (0.48 bar @ 45 m <sup>3</sup> /hr)
Maximum Operating Pressure	200 PSI (13.8 bar)
Flange Connections	U.S. ANSI B16.1 / AWWA Class 125
Test Ports	NPT
Register	Fully electronic sealed register with programmable registration (Gal. /Cu.Ft./ Cu. Mtr. / Imp. Gal. / Acre Ft.) Programmable AMR/AMI reading Guaranteed 10-year battery life
NSF Approved Materials	Maincase: Coated Ductile Iron Measuring Chamber: Thermoplastic Rotor "Floating Ball": Thermoplastic Radial Bearings: Hybrid Thermoplastic Thrust Bearings: Sapphire/Ceramic Jewel Magnets: Ceramic Strainer Screen: Stainless Steel Strainer Cover: Coated Ductile Iron